

**CURB CONSTRUCTION**

- 1) WELDED
- 2) FINGERLOCK

-ALL WELDING CONSTRUCTION CERTIFIED TO ANSI/AWS D1.3 STRUCTURAL WELDING CODE-SHEET METAL

-SELF-DRILLING SCREW SHALL MEET ASTM C1513 SPECIFICATION AND INSTALLED PER AISI-S100

-NO GAP IS ALLOWED BETWEEN TWO METAL SHEET SURFACES WHERE SHEET METAL SCREW IS CONNECTED

ALL WORK SHALL CONFORM TO THE STANDARD OF 2015 INTERNATIONAL BUILDING CODE & 2016 CALIFORNIA BUILDING CODE.

**SEISMIC DESIGN CRITERIA**

-SDS = 1.5      ap = 2.5  
-I = 1.5      Rp = 6.0

**WIND DESIGN CRITERIA**

-MAX 60 FT TALL BUILDING  
-EXPOSURE C  
-130 MPH, 3 SECOND GUST WIND

**NOTE:**  
INSTALLER TO VERIFY WITH A LICENSED STRUCTURAL ENGINEER IN THE CORRESPONDING STATE THE ADEQUACY OF THE STRUCTURE FOR LOADS IMPOSED BY THE UNIT AND THE CURB IN ADDITION TO ALL OTHER LOADS.  
-INSTALLER TO VERIFY WITH A LICENSED STRUCTURAL ENGINEER IN THE CORRESPONDING STATE THAT THE SEISMIC AND WIND DESIGN CRITERIA NOTED ON THIS DRAWING ARE ADEQUATE FOR THE SITE SPECIFIC VALUES. OTHERWISE, CONTACT CANNON FABRICATION FOR A SITE SPECIFIC ANALYSIS AND DRAWINGS.

**CURB AND UNIT INFORMATION**

16 GAUGE GALVANIZED STEEL CURB

1005-CB11*-CBCG	11"	173 LBS.
1005-CB14*-CBCG	14"	206 LBS.

MAX UNIT OPERATING WEIGHT 900 LBS  
CGX FROM CORNER = 34.13" PARALLEL TO LENGTH  
CGY FROM CORNER = 21.63" PARALLEL TO WIDTH  
CGH FROM BOTTOM OF UNIT = 20.25"

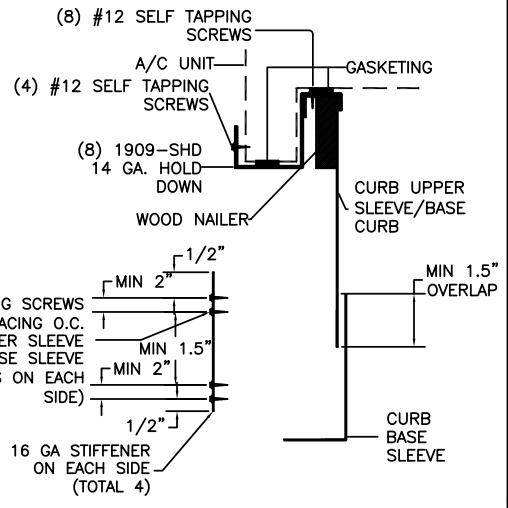

**ANCHORAGE DETAILS TO ROOF:**

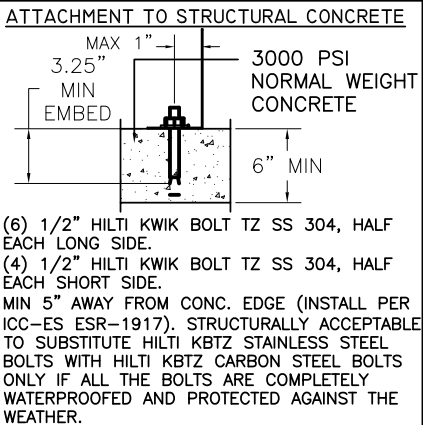
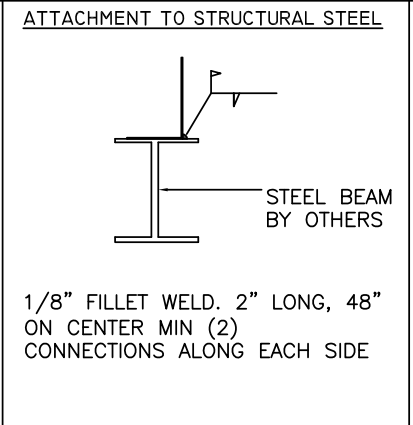
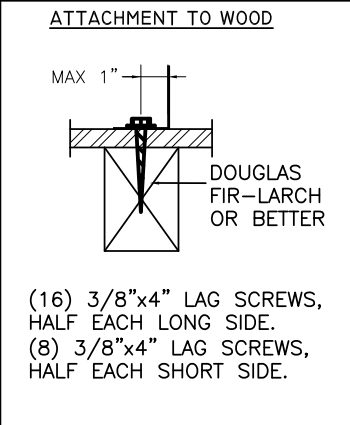
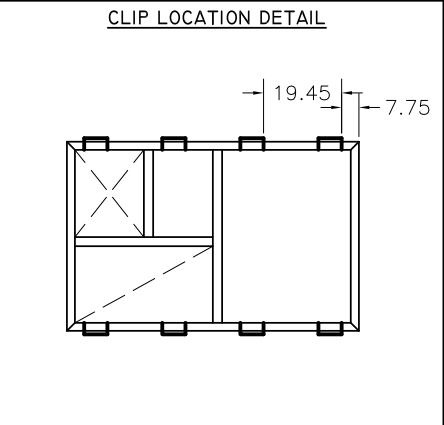

**STRUCTURAL REVIEW BY:**

**MARTIN & associates**

JOHN A. MARTIN AND ASSOCIATES  
Structural Engineers  
950 South Grand Ave., 4th Floor  
Los Angeles, California 90015  
Phone (213) 483 6490  
Fax (213) 483 3084  
Job No.: 13001



182 GRANITE STREET, SUITE 101, CORONA, CA 92879  
PHONE: (951)278-1830 FAX: (951)278-8444 www.canfab.com canfab@canfab.com

FOR: CARRIER	
PART NO: 1005-CB***-CBCG	PROJECT:
ENGINEER: LD	DISTRIBUTOR:
DRAWING NO: 1005CA.DWG	DATE: 7.30.18
APPROVED BY:	DATE: / /

WELDED ROOF CURB ASSEMBLY

- (A) REMOVE CONTENTS (WELDED UPPER CURB, WELDED LOWER CURB SLEEVE, 2-STIFFENERS, SCREW PACKAGE & GASKETING) FROM SHIPPING PACKAGE. SLIDE ROOF CURB OVER BASE SLEEVE. ADJUST THE PITCH OF THE ROOF CURB TO DESIRED ANGLE.
- (B) INSTALL GASKET AROUND THE TOP FLANGE OF THE ROOF CURB. YOU WILL NEED TO DOUBLE UP THE GASKET AROUND THE SUPPLY AND RETURN OPENINGS.
- (C) USING THE SCREWS AND PRE-PUNCHED HOLES PROVIDED. INSTALL THE STIFFENERS ACCORDING TO THE DIMENSIONS ON THE SUBMITTAL. BE SURE TO POSITION STIFFENER TO ALLOW A MINIMUM OVERLAP OF 1.5" BETWEEN THE UPPER AND LOWER CURB SLEEVES.

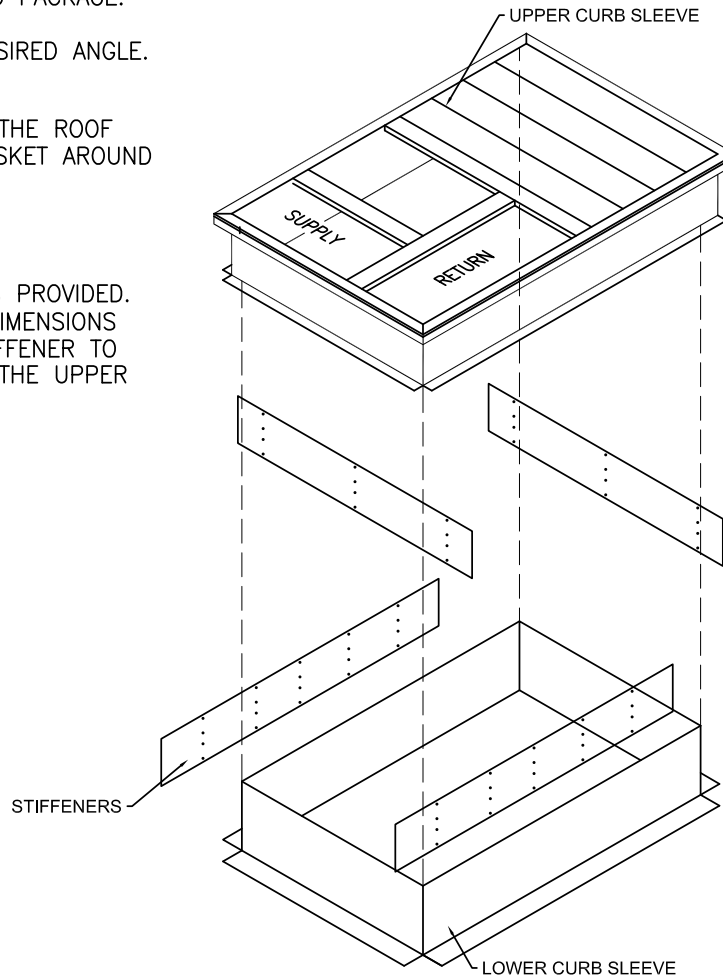

1005-CB11W/14W-CBCG	
PART NUMBER	QTY
1005-CB**W-CBCG-01A	2
1005-CB**W-CBCG-01B	2
1005-CB**W-CBCG-02A	2
1005-CB**W-CBCG-02B	2
1005-CB**W-CBCG-03A	1
1005-CB**W-CBCG-03B	1
1005-CB**W-CBCG-03C	1
1005-CB**W-CBCG-04	4
1005-CB**W-CBCG-05A	2
1005-CB**W-CBCG-05B	2
1312-WOOD	67.375" (SIDE)
1312-WOOD	37.1875" (END)
ASN10018GS	4
14135GASKET	1 ROLL
1034TEK	85



182 GRANITE STREET, SUITE 101, CORONA, CA 92879

PHONE: (951)278-1830 FAX: (951)278-8444 www.canfab.com canfab@canfab.com

FOR: CARRIER ADJUSTABLE PITCH CURB  
FIELD INSTALLATION INSTRUCTIONS

PART NO: 1005-CB\*\*W-CBCG

PROJECT:

ENGINEER: LD

DISTRIBUTOR:

DRAWING NO: 1005CA.DWG

DATE: 8.20.18

APPROVED BY:

DATE: / /



CANNON FABRICATION INC

182 GRANITE STREET, SUITE 101, CORONA, CA 92879

PHONE: (951)278-1830 FAX: (951)278-8444 www.canfab.com canfab@canfab.com

FOR: 1005-CB\*\*W-CBCG  
EXPLODED VIEW

PART NO: 1005-CB\*\*W-CBCG

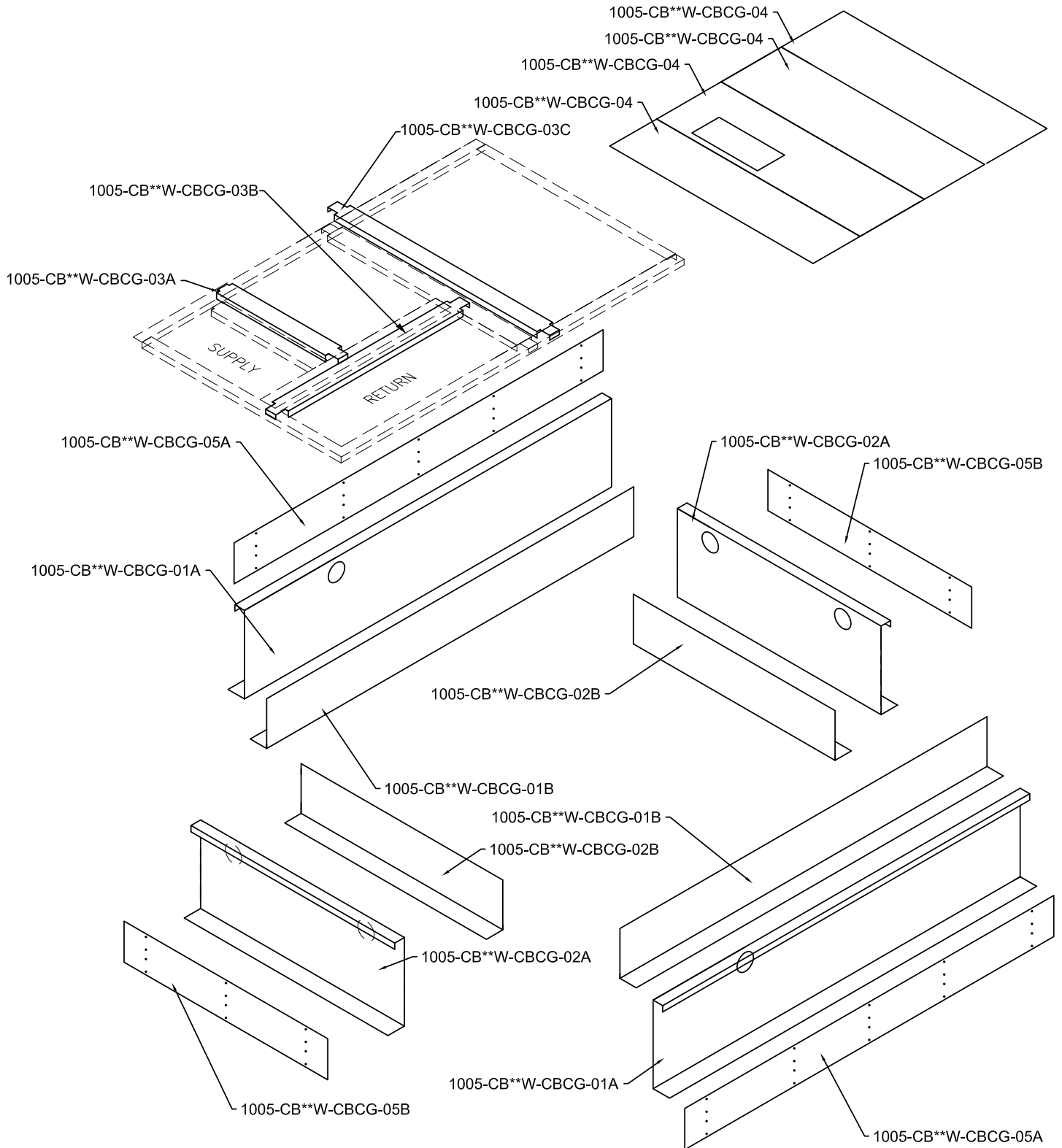

PROJECT:

DATE: 8.20.18

ENGINEER: LD

DISTRIBUTOR:

DRAWING NUMBER: 1005CA.DWG



CANNON FABRICATION INC

182 GRANITE STREET, SUITE 101, CORONA, CA 92879

PHONE: (951)278-1830 FAX: (951)278-8444 www.canfab.com canfab@canfab.com

FOR: 1005-CB\*\*W-CBCG  
PARTS LIST

PART NO: 1005-CB\*\*W-CBCG

# 1005-CB\*\*W-CBCG-PARTS LIST

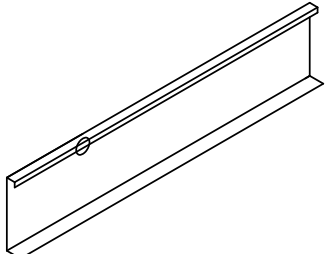
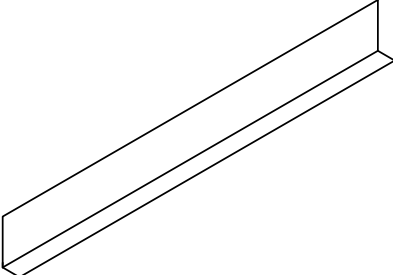
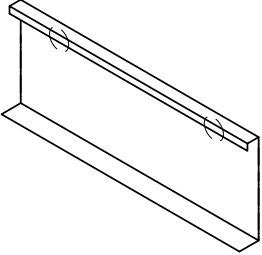
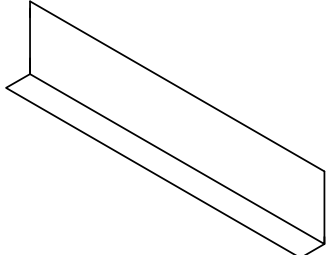
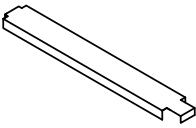
PART #	QTY	
1005-CB**W-CBCG-01A	2	
1005-CB**W-CBCG-01B	2	
1005-CB**W-CBCG-02A	2	
1005-CB**W-CBCG-02B	2	
1005-CB**W-CBCG-03A	1	

PROJECT:

DATE: 8.20.18

ENGINEER: LD

DISTRIBUTOR:

DRAWING NUMBER: 1005CA.DWG



182 GRANITE STREET, SUITE 101, CORONA, CA 92879

PHONE: (951)278-1830 FAX: (951)278-8444 www.canfab.com canfab@canfab.com

FOR: 1005-CB\*\*W-CBCG  
PARTS LIST

PART NO: 1005-CB\*\*W-CBCG

## 1005-CB\*\*W-CBCG-PARTS LIST

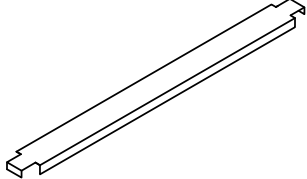
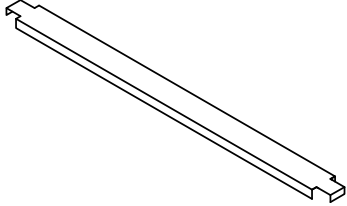
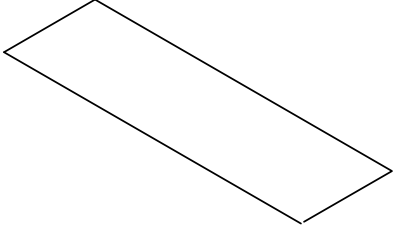
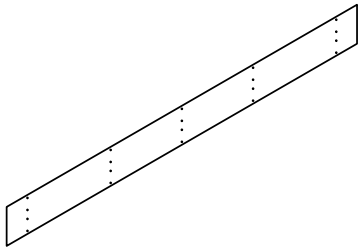
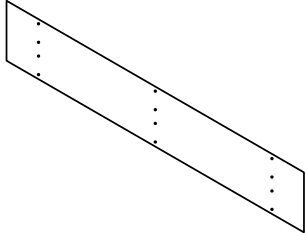
PART #	QTY	
1005-CB**W-CBCG-03B	1	
1005-CB**W-CBCG-03C	1	
1005-CB**W-CBCG-04	2	
1005-CB**W-CBCG-05A	2	
1005-CB**W-CBCG-05B	2	

PROJECT:

DATE: 8.20.18

ENGINEER: LD

DISTRIBUTOR:

DRAWING NUMBER: 1005CA.DWG